

PELLET MILL

FEATURES

- Homogeneous, high quality pellet production
- Speed controlled feeding screw
- Conditioner with pre-adjusted paddles in the shaft and a steam adding treatment
- Pellet production with requested diameter
- Equipped with all steam accessories
- Dies and rolls imported from Germany
- Single or twin engine for operational conditions
- Safety pin for immediate charges or impacts
- A wide range of capacities
- Low investment, production and maintenance costs
- Maximum flexibility and versatility
- Spare parts support and customer service

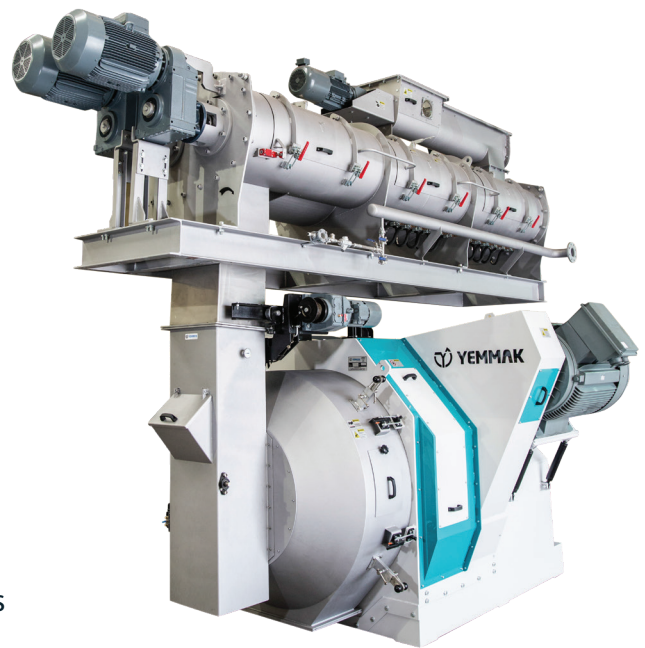

LIVESTOCK POULTRY BIOMASS CHEMICALS



AREAS OF USAGE

- Compound feed mills
- Food plants
- Chemical plants
- Wood sawdust pelleting mills
- Straw pelleting mills
- Alfalfa pelleting mills
- Fertilizer pelleting mills

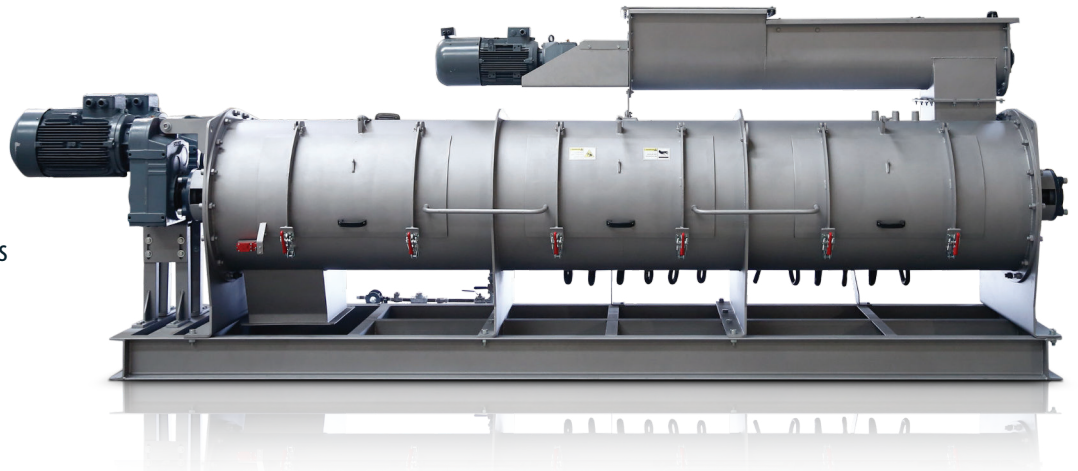

PELLET MILL

Pelleting process in the compound feed industry increase due to the pellet feed's physical (ease of transport, declining homogenization and growing intensity) and the positive impact on the performances of the animals which are fed with this feed. The positive impact of the pellet feed depends considerably on the pellet's physical quality. During the pellet feed production, it must be aimed to protect its form until it reaches animal's feeders. The features offered (physical and chemical features, formulation) and the technology applied to it (water steam, tempering, oil addition, matrix features and cooling) affects the feed quality. It is possible to produce pellet feed at a required quality by taking aforementioned parameters. Yemmak pellet mills work at the optimum capacity in small or large facilities. Semi-finished materials are transferred to the conditioner unit with the feeding screw.

After the materials are conditioned with steam in the conditioner unit, they are transferred to the pressing section. Materials which are evenly distributed in the pressing section, are pressed between rolls and the die. Required pelleting can be done with the adjustable knives. Yemmak pellet mills offer easy transportation and stocking. It helps digestibility. It prevents disintegration. It helps achieving minimum loss during consumption. It ensures higher benefit from the unit volume compared to dust feeds. The feed that is cooked with steam, becomes more digestible for the animals since the starch in it becomes gelatinized. It kills the harmful, pathogen bacterias (Salmonella). The cost of stocking and transportation of the feed becomes more affordable after getting denser by pelleting. Other than the feed industry, it is used broadly for pelleting bran, pulp, wood, compost, garbage, hop, bagasse and sugar beet pulp.

PELLET PRESSES WITH AUTOMATIC ROLLER

The control of the pressing distance between the roller and the die is automatically adjusted. Thus, the stopping time of the machine is minimized comparing to the manual presses, increasing the capacity and ensuring a homogenous pelletization. Special sensors mounted on the mechanism, in case of sudden and irregular loading conditions that may occur under operating conditions, allows automatical protection. Thus, unexpected stops in production are prevented. Automatic speed control of the rollers during pelleting is achieved by means of the roller speed sensors adapted mounted on the machinery.



CONDITIONER

To obtain the best results from steam adding treatment, the paddles on the conditioner shaft are adjustable so that maximum conditioning time can be obtained. According to needs conditioning, it can be prepared as double deck.

DIFFERENTIAL DIAMETER CONDITIONER

In the process, by adding steam and fluids to the semi-finished product, it is ensured that the feed is mixed homogeneously. Thanks to the two shafts that run at different speeds and adjustable paddles mounted on them, the retention and mixing time can be adjusted as desired. The body is completely made of AISI 304 material. The gelatinization of the steam-mixed product starch in the DDC conditioning is increased. Also, kills salmonella bacteria in feed.

BENEFITS

- High efficiency by making homogenous mixture with steam
- Long retention time
- Easy maintenance and installation
- High amount of molasses, oils or other fluids adding to the mixture
- Suitable for use in existing pellet presses

DIES AND ROLLS

Dies and rolls are all imported and they are made from German patent alloy steel.

DOOR

The pellet mill door is manufactured from stainless steel. Two pellet cutting knives are assembled on a separate part of the body so that the door can be opened in safety without altering the settings of the knives.

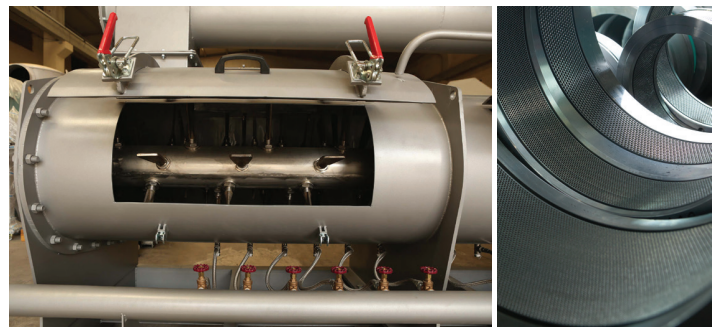
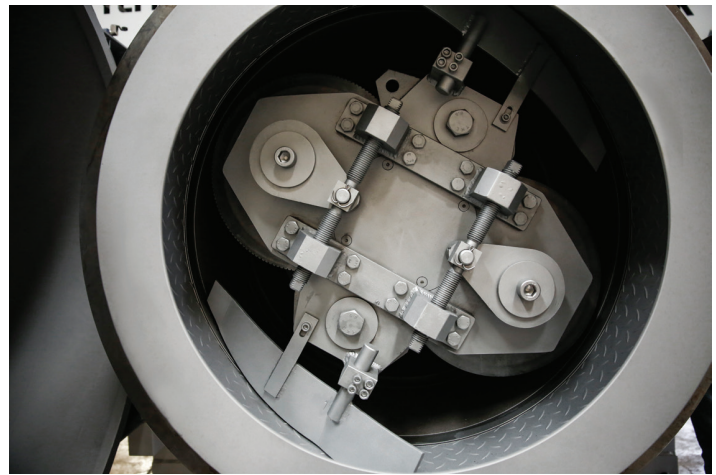

THE ADVANTAGES OF PELLETING IN THE FEED INDUSTRY

- The digestibility of the material increases with grinding, heat, pressure and steam.
- The taste becomes enhanced and the unit of energy increases after molasses and oil are used.
- It ensures homogeneous feed for animals.
- It prevents the diseases that can be transmitted through feeds.
- Dust output is prevented.
- Infestation decreases, and the microorganism reproduction is kept low.
- Storage loss due to sunlight oxidation declines.
- Takes smaller space in transportation, increases the mechanization while carrying and feeding.
- Allows addition of liquid feeds upon the pellet



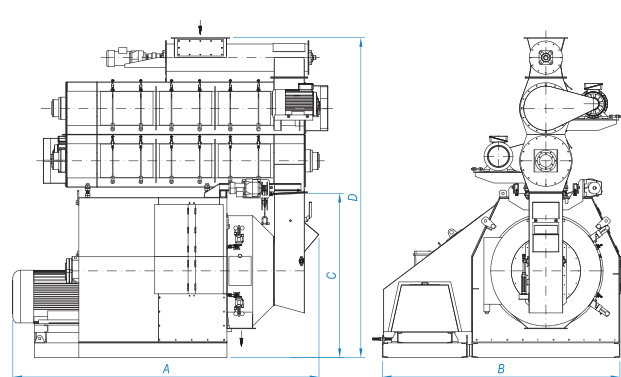

SINGLE DRIVE (SD)

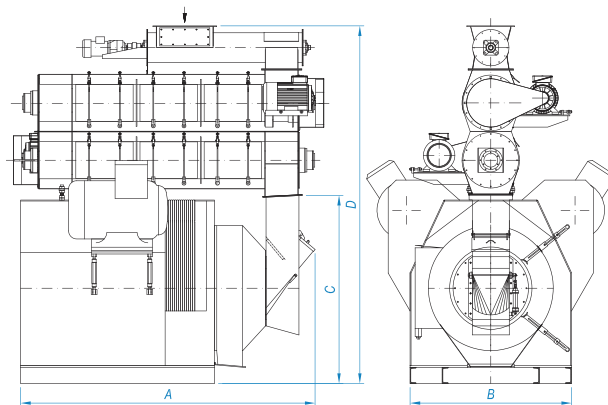

DOUBLE DRIVE (DD)

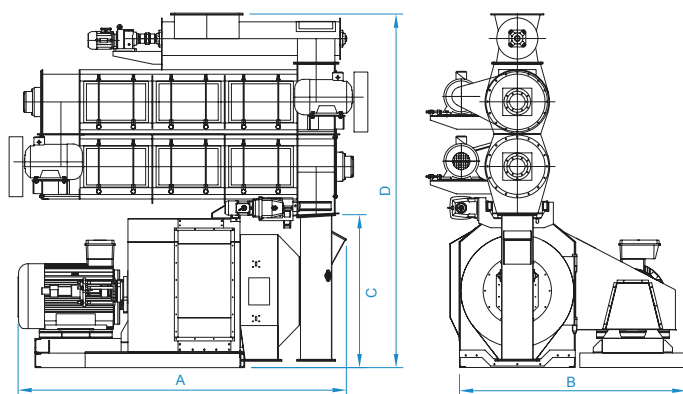

SINGLE DRIVE AUTOMATIC ROLLER ADJUSTMENT (SDA)

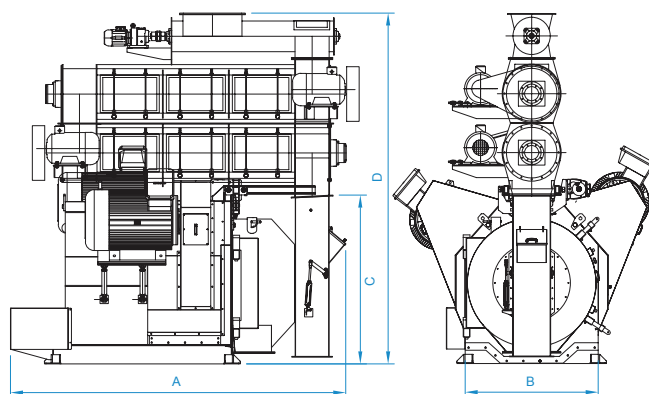

DOUBLE DRIVE AUTOMATIC ROLLER ADJUSTMENT (DDA)

MODEL		DIMENSIONS(mm)				MOTOR POWER (kW)	CONDITIONER POWER (kW)	FEEDER POWER (kW)	DIE		CAPACITY (ton/h)
		A	B	C	D				DIAMETER (mm)	WIDTH (mm)	
PM1	304/75 SD	1480	1740	880	1688	45 KW	4	2,2	303	75	max. 3 (animal feed)
	420/78 SD										
P2	420/108 SD	2130	2100	1250	3045	90	7,5	3	420	108	max. 10 (animal feed)
	420/138 SD									138	
P3	520/78SD	3525	2320	1520	2690	160	7,5	2,2	520	78	1-2,5 (wood pellet)
	520/138 SD									138	
	520/178 SD	3240	2320	1520	3320	160	7,5	3	520	178	max. 15 (animal feed)
	520/138 DD									138	
	520/178 DD									178	
PM4	660/178 SDA	3600	2485	1680	3765	160-200	11-15	4-5,5	660	178	max. 20 (animal feed)
	660/228 SDA									228	
	660/265 SDA									265	
	660/138 DDA	3000	1290	1550	3765	90x2	110x2	132x2	138		
	660/178 DDA								178		
	660/228 DDA								228		
PM5	900/138 SD	4250	3000	2110	3600	315-355	18,5-22	4	900	138	4-5 (wood pellet)
	900/178 SDA					178					
	900/228 SDA	4350	2810	2080	4280	315	18,5-22	5,5-7,5	900	228	max. 30 (animal feed)
	900/300 SDA									300	
	900/228 DDA									228	
	900/265 DDA	4040	1600	2030	4230	185x2	200x2			265	
	900/300 DDA									300	

SD :Single drive SDA :Single drive automatic roller adjustment DD:Double drive DDA:Double drive automatic roller adjustment



61 Depot Street | Buffalo, NY 14206
www.hammermills.com | info@hammermills.com | 1-800-447-4634



600 Evler Mah. Balikesir Asf. Sol Taraf No:96, 10201 Bandirma/Balikesir
www.yemmak.com | T: +90 266 733 83 63 (3 Hat) | F: +90 266 733 83 66