

# SchutteBuffalo

## Full Circle Screen Hammer Mills



# Table of Contents

Introduction.....	3
How does a hammer mill work?.....	4
Screen coverage comparison.....	5-6
Applications.....	7
Brochures.....	8-16
Contact us.....	17

**Schutte**Buffalo

## FULL CIRCLE SCREEN HAMMER MILLS



Size reduction equipment comes in a wide variety of shapes and sizes: vertical or horizontal hammer mills, jaw crushers, roller mills and ram-fed grinders, just to name a few. For the most part, the size and shape of the mill/grinder/crusher plays a key role in the functionality of the machine, and for the applications it is best suited for. Nowhere is this truer than with the **Full Circle Screen Hammer Mill**.





## How does a hammer mill work?"

- When material enters the grinding chamber, it is repeatedly struck by hammers that flail out as the shaft spins.
- A combination of these hammer blows, particle on particle impact, and impact with the walls of the grinding chamber all work together to break the material down.
- The material remains in the grinding chamber until it is reduced to a size that will pass through the screen.

## A peek inside...

The full circle screen hammer mill gets its name from the **300 degree screen coverage of the rotor**, while all other styles of hammer mills typically have closer to 180 degree coverage of the rotor.

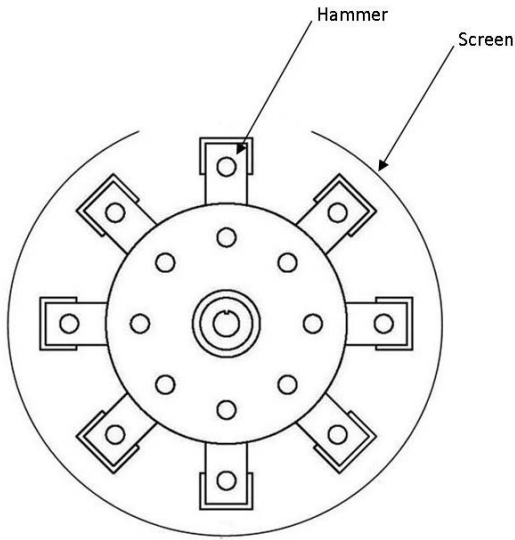

**Full circle screen  
hammer mill**

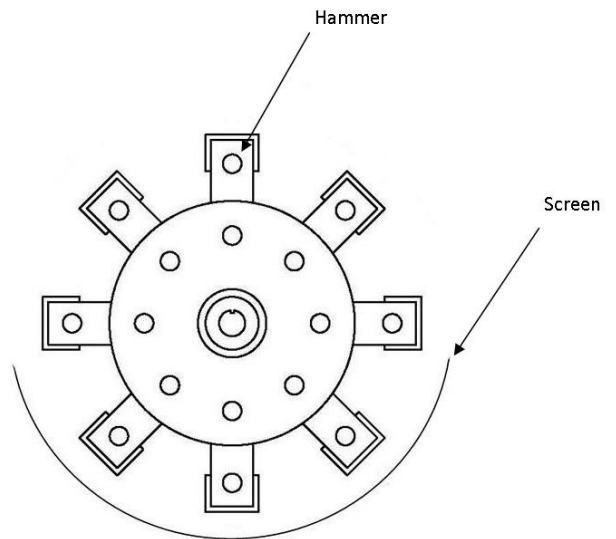

**Industrial  
hammer mill**

The larger the screen area, the greater the opportunity for the material to evacuate the mill.

As a result...

Full circle screen hammer mills have the highest throughput to horsepower ratio of all hammer mill styles



## Ideal applications

To achieve the circular, nearly full coverage of the rotor requires that the screen be somewhat pliable, and therefore relatively thin. In addition, the full circle screen mills use thin, sometimes notched hammers that reduce material with a tearing/grinding action, as opposed to the pulverizing effect of the large, heavy hammers often used in the industrial hammer mills. As a result, the full circle mills are best suited for light, easy to grind materials that do not require initial grinding against a breaker plate.

Such as:

A word cloud of materials suitable for full circle screen hammer mills. The words are arranged in a roughly circular shape. The largest words are 'herbs and spices' in red, 'shavings' in grey, and 'grains' in grey. Other words include 'corn', 'planer', 'hogged wood scrap', 'sawdust', 'wood chips', 'barley', 'oats', 'rye', 'soybeans', 'wheat straw', and 'grasses'.

barley oats corn  
planer shavings  
hogged wood scrap grasses  
rye herbs and spices  
wood chips sawdust  
soybeans grains  
wheat straw

## Brochures

**Schutte**Buffalo





## 24 Series Circ-U-Flow Hammer Mill

The high-speed 24 Series Circ-U-Flow hammer mill is designed for mid-range production grinding of a variety of products. The nearly full circle screen translates to a large screen open area and thus the highest possible production rates on materials that do not require initial grinding against a breaker plate. Suitable for gravity or pneumatic evacuation.

### Applications:

- Alfalfa
- Barley
- Corn
- Oats
- Planer shavings
- Rye
- Sawdust
- Sorghum
- Soybeans
- Spices
- Straw
- Wheat
- ... and more

### End Products/Uses:

- Agricultural products
- Animal feed
- Biodiesel
- Boiler fuel
- Cellulosic ethanol
- Pellets and Briquettes
- Sizing for packaging

**SchutteBuffalo**

The Leaders in Size Reduction

Quality, since 1928

[www.hammermills.com](http://www.hammermills.com)

# 24 Series Technical Specifications

Model	Housing	Shaft Diameter	Rotor Width	Rotor Diameter	Bearing Size	Power Range	Screen Area	Tip Speed
24-10	1/2" (12mm)	2 3/4" (70mm)	10" (250mm)	24" (610mm)	2 7/16" (60mm)	25-40 hp (20-30 kW)	600 sq inches (3870 sq cm)	22,600
24-15	1/2" (12mm)	2 3/4" (70mm)	15" (380mm)	24" (610mm)	2 7/16" (60mm)	50-60 hp (40-50 kW)	900 sq inches (5810 sq cm)	22,600
24-20	1/2" (12mm)	3 1/4" (80mm)	20" (510mm)	24" (610mm)	2 7/16" (60mm)	75-100 hp (60-70 kW)	1200 sq inches (7740 sq cm)	22,600
24-24	1/2" (12mm)	3 1/4" (80mm)	24" (610mm)	24" (610mm)	2 7/16" (60mm)	100-150 hp (70-110 kW)	1440 sq inches (9290 sq cm)	22,600

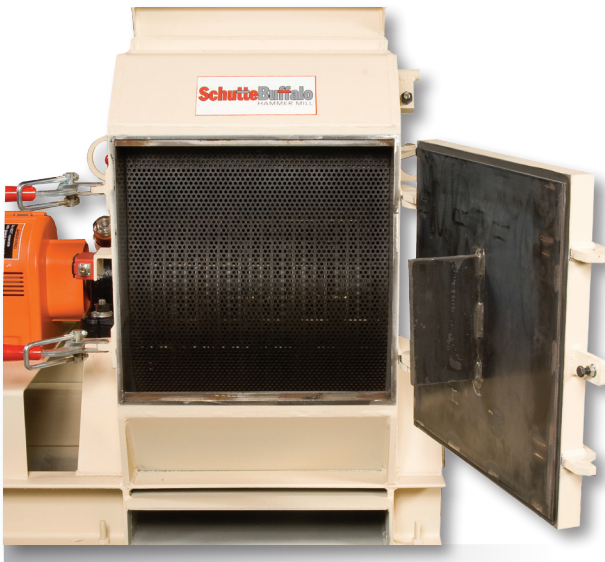

Vertical access door allows for easy screen change, maintenance, and rotor inspection.

## Key Features:

- Available in four standard mill widths (10", 15", 20" and 24") with custom sizes available.
- Screen discharge areas from 600 to 1,440 square inches.
- High speed (3,600 RPM) rotor assembly with four-way reversible hammers.
- Variety of screen sizes from 3" to .020".
- Dual directional rotors.
- Easy access to mill's interior through dual access doors.
- Optional rotary feeders, magnets and de-stoners available.



## 44 Series Circ-U-Flow Hammer Mill

Low speed (1,800 RPM), high production. Nearly full circle screen coverage of the 44" diameter rotor. The 44 Series Circ-U-Flow hammer mill is designed for very high production grinding of a wide variety of products. The nearly full circle screen translates to a larger screen open area, allowing the highest possible production rates on materials that do not require initial grinding against a breaker plate. Suitable for either gravity or pneumatic evacuation.

### Applications:

- Alfalfa
- Barley
- Corn
- Herbs and Spices
- Planer shavings
- Rye
- Sawdust
- Sorghum
- Soybeans
- Straw
- Wheat
- ... and more

### End Products/Uses:

- Agricultural products
- Animal feed
- Biodiesel
- Boiler fuel
- Cellulosic ethanol
- Pellets and Briquettes
- Sizing for packaging

# 44 Series Technical Specifications

Model	Housing	Shaft Diameter	Rotor Width	Rotor Diameter	Bearing Size	Power Range	Screen Area	Tip Speed
44-13	3/4" (20mm)	3 1/4" (80mm)	12 1/2" (320mm)	44" (1120mm)	2 15/16" (70mm)	75-100 hp (60-70 kW)	1375 sq inches (8870 sq cm)	20,700
44-17	3/4" (20mm)	3 1/4" (80mm)	17 1/2" (440mm)	44" (1120mm)	2 15/16" (70mm)	100-125 hp (70-90 kW)	1925 sq inches (12420 sq cm)	20,700
44-24	3/4" (20mm)	3 1/4" (80mm)	24" (610mm)	44" (1120mm)	2 15/16" (70mm)	125-150 hp (90-110 kW)	2640 sq inches (17030 sq cm)	20,700
44-30	3/4" (20mm)	5" (130mm)	30" (760mm)	44" (1120mm)	3 7/16" (90mm)	200-300 hp (150-220 kW)	3300 sq inches (21290 sq cm)	20,700
44-48	3/4" (20mm)	6 3/8" (160mm)	48" (1220mm)	44" (1120mm)	3 7/16" (90mm)	350-400 hp (260-300 kW)	5280 sq inches (34070 sq cm)	20,700
44-60	1" (25mm)	6 3/8" (160mm)	60" (1530mm)	44" (1120mm)	4 7/16" (115mm)	400-600 hp (300-450 kW)	6600 sq inches (42580 sq cm)	20,700



Available in six sizes, with rotor widths ranging from 13" to 60".



Quick release levers allow for easy screen change, maintenance and rotor inspection.

## Key Features:

- Six mill widths (13", 17", 24", 30", 48" and 60"); Also available in custom sizes.
- Screen discharge areas from 1,375 to 6,600 square inches.
- Low speed (1,800 RPM) rotor assembly with four-way reversible hammers.
- Optional ribbed plate attrition zone.
- Dual directional rotors.
- Optional rotary feeders, de-stoners and magnets.
- Variety of screen sizes from 3" to .020".
- Easy access to mill's interior through dual access doors.
- Optional side liner plates for moderately abrasive materials.

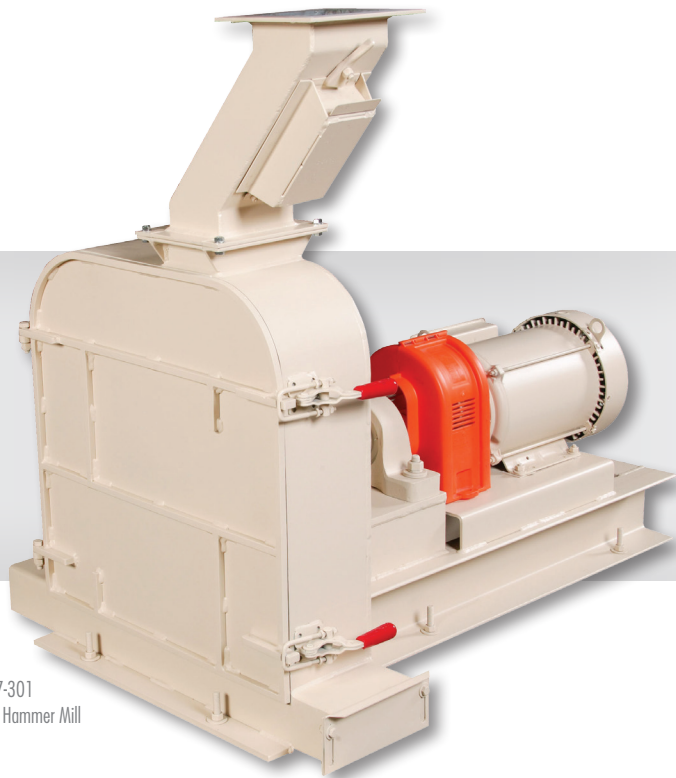

Model 18-7-301  
Circ-U-Flow Hammer Mill

## Model 18-7-301 Circ-U-Flow Hammer Mill

The model 18-7-301 Circ-U-Flow is a high speed full circle screen hammer mill ideal for pilot scale or full industrial processing of a wide variety of products. The nearly full circle screen coverage of the rotor translates to a large open area and thus the highest possible production rates on materials that do not require initial grinding against a breaker plate. Optional fully integrated pneumatic evacuation system substantially increases throughput and keeps work environment clean and dust free. The Model 18-7-301 is ideal for processing herbs, spices, roots, wood shavings, and a wide variety of agricultural products to the exact desired finished particle size.

### Applications:

- Alfalfa
- Barley
- Corn
- Oats
- Planer shavings
- Rye
- Sawdust
- Sorghum
- Soybeans
- Spices
- Straw
- Wheat
- And more

### End Products/Uses:

- Agricultural products
- Animal feed
- Boiler fuel
- Cellulosic ethanol
- Herbs and spices
- Pellets and briquettes
- Sizing for packaging

# Model 18-7-301 Circ-U-Flow Hammer Mill

## Technical Specifications

Model	Housing	Shaft Diameter	Rotor Width	Rotor Diameter	Bearing Size	Power Range	Screen Area	Tip Speed
18-7-301	1/4" (6mm)	1 7/8" (50mm)	7" (180mm)	18" (460mm)	2 3/16" (60mm)	10-30 hp (7-20 kW)	385 sq inches (980 sq cm)	16900



Model 18-7-301 with optional integrated pneumatic discharge system.

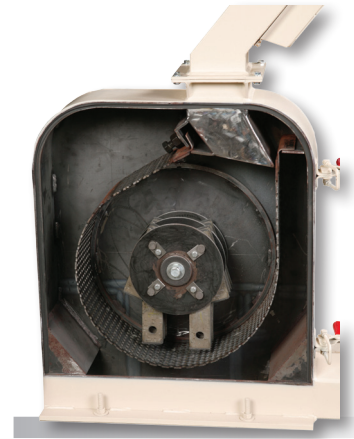

300 degree screen coverage of rotor results in the highest possible throughput per horsepower.

### Key Features:

- Pilot scale, 7" (180mm) width
- 10-30 hp motor
- High speed (3600 RPM), 18" (460mm) diameter rotor allows for high tip speed
- Dual directional rotor
- Hinged door with built-in screen support for easy access, cleaning and maintenance
- Custom built feed chute, discharge chute, and support stand designed to meet your specific feeding and collecting needs
- Optional easy to clean magnet



## Model H28 Pilot Scale Circ-U-Flow Hammer Mill

The H28 Series Circ-U-Flow is a pilot scale full circle screen hammer mill designed with laboratory testing, and small batch and craft production in mind. This compact unit features the same nearly full circle screen coverage as its larger Circ-U-Flow cousins, resulting in the highest throughput to horsepower ratio of any style of hammer mill when processing light, low density materials. Available in both carbon and stainless steel models, each with the choice of gravity or pneumatic discharge.

### Applications:

- Agricultural Products
- Brewery and Distillery Grains
- Herbs and Spices
- Light Wood Chips
- Meat and Bone Meal
- Sawdust

### End Products / Uses:

- Animal Feed
- Biofuel Feed Stock
- Culinary Herbs and Spices
- Distilled Beverages

# Model H28 Technical Specifications

Model	Housing	Shaft Diameter	Rotor Width	Rotor Diameter	Bearings	Screen Area	Power Range	Tip Speed
H28	1/4" (6mm)	1 1/8" (29mm)	3" (76mm)	12" (305mm)	1 1/8" (29mm)	120 sq Inches (305 sq cm)	5 hp (4 kW)	11,300

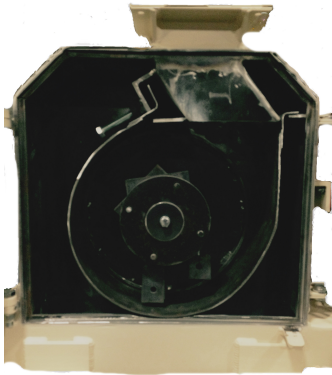

300 degree screen coverage of rotor allows for the highest throughput to horsepower to ratio of all hammer mill styles.



Quick release handles provide easy access to mill interior for routine maintenance

## Key Features:

- 5 HP motor
- 1/4" A-36 plate construction
- 12" rotor diameter
- 11,300 ft/min tip speed
- Optional pneumatic discharge
- Easy to change screens available in a variety of sizes
- Four-way reversible hammers
- Optional Variable Frequency Drive



## Contact us

[Request a quotation](#)

Website: [www.hammermills.com](http://www.hammermills.com)

Contact us: [info@hammermills.com](mailto:info@hammermills.com)

**Schutte**Buffalo